



DEMONSTRATION PROJECT OVERVIEW

DC POWERING ARCHITECTURE FOR DATA CENTERS: DC POWERING AT THE FACILITY LEVEL

What it is: Joint industry & California Energy Commission sponsored demonstration
When: April 2006 to September 2006
Where: Sun Microsystems, Newark, CA
More info: Scheduled open house and "virtual" open house June – July 2006 see <http://hightech.lbl.gov/>

BACKGROUND

An alternative approach to conventional AC power uses a DC power distribution scheme throughout a data center. Most data center server racks are not currently powered this way, but with the advent of servers on the market that can operate with either AC or DC, it is possible to use the DC powering approach, thus eliminating extra power conversion steps and losses. Other benefits include reduced cooling needs, higher equipment densities, and reduced heat-related failures.

DEMONSTRATION GOAL AND OBJECTIVES

A stakeholder group has been formed by industry and the CEC to investigate:

1. Whether or not DC powered server(s) and/or server racks can provide the same level of functionality and computing performance when compared to similarly configured and operating servers (and/or server racks) containing AC powered server(s), as measured with industry standard measurement devices and software tools.
2. Document any efficiency gains from the elimination of multiple conversion steps in the delivery of DC power.
3. Feasibility for both facility-level as well as rack-level DC conversion and delivery.
4. Identify issues/best practices and make recommendations for implementation.

FACILITY-LEVEL DEMONSTRATION

This demonstration project focuses on DC conversion at the Data Center (or Facility) level. This approach converts the facility's high-voltage AC into high-voltage DC and delivering it to the equipment racks via high-voltage DC buss (the possible DC voltages under consideration range from 350V up to 500V – the current consensus is at 380 VDC). Further voltage conversion/step down can be handled at the rack or equipment level as needed. This approach concentrates the DC conversion into one unit/location for the whole facility, removing the AC to DC conversion function from the equipment. Figures 1 and 2 contain representations of this option.

Concurrently underway is a demonstration of a rack-level DC distribution – please contact one of the project contacts below to get additional information on these efforts.

Some major advantages of this Facility-Level option include:

- Only one rectifier stage is needed for DC conversion
- Possible efficiency gains from the reduction of multiple conversion steps
- Allows for better cooling management

Considerations regarding this approach:

- Suitable only for new server rack configurations
- Requires data center infrastructure changes.

PROJECT PARTICIPANTS

A listing of project participants is provided below. A complete listing is available from the project contacts.

- | | | |
|------------------------------------|-----------------------------------|-------------------------------|
| ▪ Alindeska Electrical Contractors | ▪ Hewlett Packard | ▪ RTKL |
| ▪ Baldwin Technologies | ▪ Intel | ▪ SatCon Power Systems |
| ▪ CCG Facility Integration | ▪ Liebert Corporation | ▪ Square D/Schneider Electric |
| ▪ Dranetz-BMI | ▪ Morrison Hershfield Corporation | ▪ Sun Microsystems |
| ▪ Dupont Fabros | ▪ NTT Facilities | ▪ TDI Power |
| ▪ EDG2, Inc. | ▪ NexTek | ▪ Universal Electric Corp. |
| ▪ EYP Mission Critical | ▪ Pentadyne | ▪ Verizon Wireless |

Project Contacts

My Ton
 Ecos Consulting
 503.525.2700 ext. 104
mton@ecosconsulting.com

Brian Fortenbery
 EPRI Solutions
 865.218.8012
bfortenbery@epriolutions.com

Bill Tschudi
 Lawrence Berkeley National Laboratory
 510.295.2417
wftschudi@lbl.gov



Figure 1. Block Diagram of Proposed Demonstration Set-Up
Source: Intel & Sun

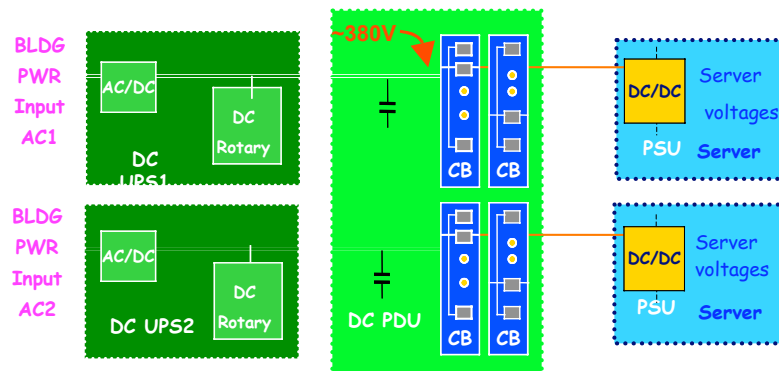

Figure 2. Details of Proposed Demonstration Set-Up
Source: BTI

